

ORDER # _____
S/N: _____
(REQUIRED FOR WARRANTY)



1.0/1.7 WHOLE HOUSE FAN INSTALLATION AND OPERATION MANUAL

© ALL RIGHTS RESERVED | AIRSCAPE INC.



WHAT'S IN THE BOX

Prior to beginning installation, please verify that you received all the accessories with the whole house fan. The package should include:

- fan/damper assembly
- grille (including 6 powder coated wood screws)
- adhesive backed foam gasket
- 6 wood screws
- dual-speed wall switch and plate **or** LCF Wireless Remote Kit **or** DLX Controller

CONGRATULATIONS on your purchase of the AirScape Whole House Fan. This fan is designed to provide you with quiet, economical cooling for many years.

Please take a few minutes to read over the sections below to make sure you are prepared for the installation. The building owner/occupant should read the section "Where to Locate" below so that the unit will be correctly located to maximize usefulness and economy of operation.

If you (or your installer) have any questions regarding the installation, operation, or maintenance, please call your supplier or retailer who has the experience and training to assist you.

WHAT YOU WILL NEED

- flat head screwdriver
- cordless screwdriver w/ Philips head bit
- lumber, matching the dimensions of the attic joists
- high quality latex caulk
- drywall cutting tool
- 3 wire cable 20g or larger (thermostat wire will work) and electrical box for mounting wall switch (Only if no other controller has been ordered with unit)

WHERE TO LOCATE

Let's start with a little theory of operation: As your house heats up during the summer day, a large amount of heat is retained in the building structure. Even though many summer evenings offer very comfortable outdoor conditions, we are forced to either endure the hot conditions of our houses or turn on the air conditioning and subject ourselves to the expense and possibly unhealthy air conditions.

The solution to this problem is certainly not new. Naturally ventilated house designs and whole house fans have been around for a long time and offer some solution to this problem. AirScape Whole House Fan have been designed to run quietly and efficiently all night long. Building materials give up their heat slowly (touch the brick on your house after sunset), and this method of slow cooling extracts as much heat as possible from your house structure. Since the AirScape is one of the quietest whole house fans on the market, it also allows you to get a good night's sleep.

Guidelines for locating your whole house fan:

- Centrally located to ensure air is drawn evenly from multiple open windows
- AWAY from windows that will be opened so cool air is required to travel a long path to the fan
- At the highest point possible to exploit natural convective action
- Near an outlet or power supply to minimize electrical work
- Typically, the ideal location in a two-story home is in the open area at the top of the stairs
- Try avoid narrow spaces close to bedrooms, as this could amplify noise at night (when noise perception is strongest)

Ceiling or Wall?

Both the 1.0 & 1.7 can be mounted in the horizontal or vertical orientation. (*NOTE: For the 1.0, make sure the door hinge is in the vertical position.*) Our recommended location is in a ceiling in the horizontal orientation -- keep in mind that it makes sense to place the unit as high as possible to eliminate the hottest air first.

Figure 1 illustrates how cool air enters an open window and replaces hot air that is exhausted by the fan into the attic.

FIGURE 1 – Location

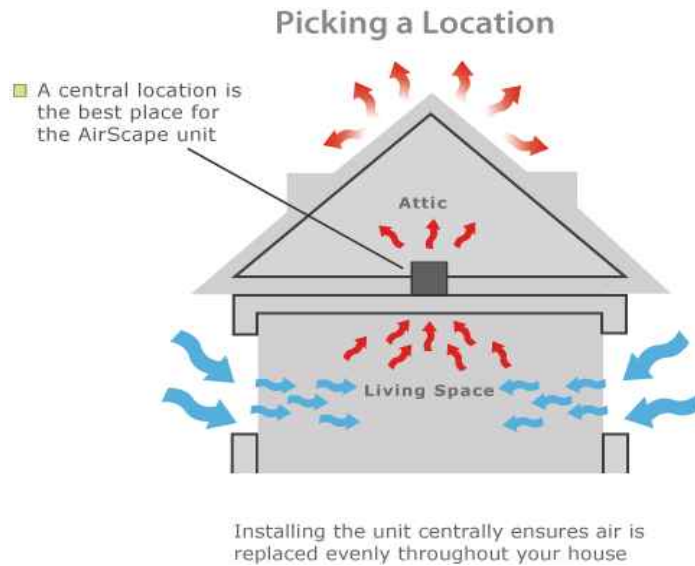

REQUIRED VENTING AREA

For the **1.7 model**, we recommend that your attic has **4 square feet** of "net-free" venting area. For the **1.0 model**, we recommend that your attic has **2 square feet** of "net-free" venting area.

First of all, let's define "net-free" area.

The "net-free" area of a vent is the total vent opening minus the loss caused by the interference of the screen or louver covering the vent.

For example, a 24" x 24" louver with an area of 4 square feet, would have a net free area of 2 square feet (this is for a particular brand of louver, but the 50% ratio of net to actual area is common).

You can obtain net-free area numbers from each manufacturer, but here is a handy table that errs on the side of caution.

Example Item	Length (inches)	Width (inches)	Fraction Net Free Area	Net Free Area (square feet)
	L	W	FNA	= L x W x FNA / 144
Louver	16	16	0.5	= 16 x 16 x 0.5 / 144 = 0.89
Ridge Vent	48	not used	0.13	= 48 x 0.13 / 12 = 0.52
Eave Vent	12	4	0.5	= 12 x 4 x 0.5 / 144 = 0.16

- In practice, less net-free area than recommended will decrease the airflow performance of the unit.
- If you are unsure as to how much net-free venting you have, please consult a roofing professional.
- Net-free venting area can be acquired by any combination of gable, eyebrow, soffit, or ridge vents, or any means that provide ventilation to the attic space.

UNIT DIMENSIONS

FIGURE 2 – 1.0/1.7 Dimensions

1.0 WHF

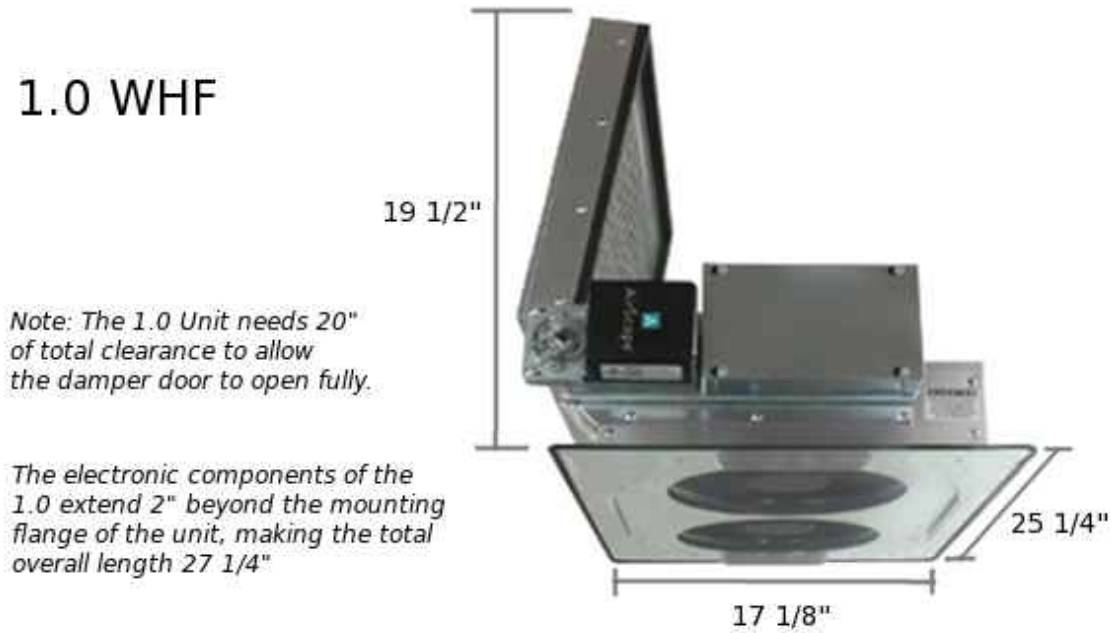

1.7 WHF



INSTALLATION - CARPENTRY

The 1.7 & 1.0 units have been designed to fit into a 14½" x 22½" wall or ceiling opening. Since most modern houses have been built with either 16" or 24" on-center (o.c.) spaced joists or studs, a simple "box" is constructed in the wall/ceiling.

Two 2x8's (to match existing 2x8 attic joists), 14½" long have been nailed in place 24" o.c. apart to form the box as shown in **Figure 4**. If your joists or trusses use 2x4, 2x6, 2x10, etc., please substitute the appropriate depth pieces. For 24" o.c. joists, place the cross pieces 16" o.c. apart, creating a box with inside dimensions of 14½"x22½". The illustrations in **Figures 5 and 6** show the fans sitting on top of 2x8 joists. The joists are 16" apart on-center and have a total distance between them of 14½".

Use a stud finder to locate the joists or studs from the living space or drill pilot holes from the attic space to outline the grille opening in the drywall ceiling or wall. Cut the opening with a drywall cutter. The opening should be 14½" x 22½".

Place the included foam tape gasket over the top of the joists, position the fan on top of the joists, and attach the unit with the wood screws (included). Do not over tighten the screws, since this may reduce the vibration isolation qualities of the foam gasket.

Use a good quality latex caulk to seal all wood-to-wood and wood-to-metal joints to create an air-tight enclosure. This is important to ensure that all air drawn in by the fan will be from inside the house.

The last step is to attach the interior grille to the joists with the included screws.

FIGURE 4 – Framing

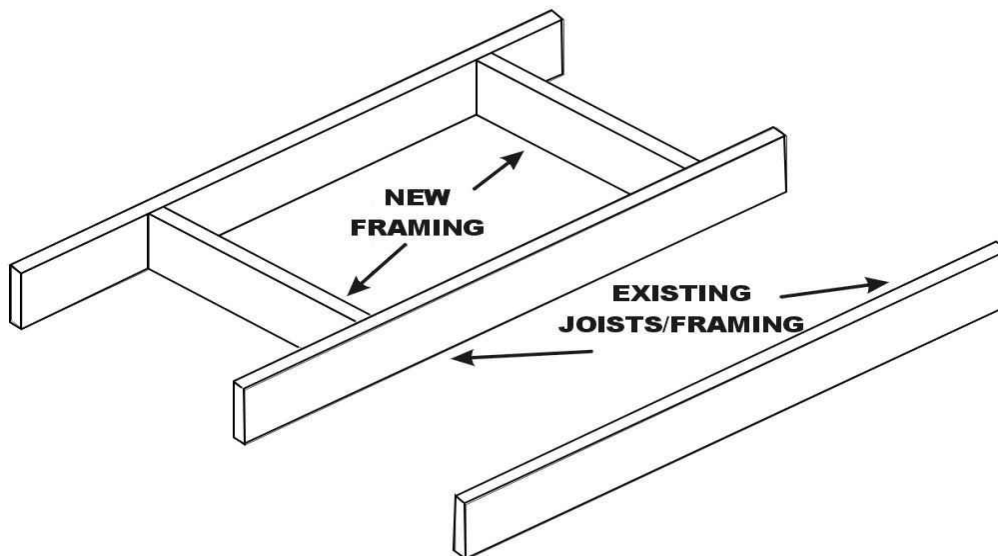

FIGURE 5 – 1.7 Installed (attic view)



FIGURE 6 – 1.0 Installed (attic view)



INSTALLATION - WIRING (LOW VOLTAGE HARDWIRED SWITCH)



Please make sure that local codes and standards are followed when performing the following steps. Make sure that the appropriate circuit breakers are turned off and that the unit is unplugged when performing these steps.

*Note: If you purchased your unit with an optional DLX Controller see Controller IOM for installation instructions. If a Wireless Remote was purchased, it has already been installed on your unit. Skip to the **START UP AND OPERATION** section.*

Step 1: Run a 3-wire cable 20 gauge or thicker for the 24v low-voltage wiring from the damper enclosure to the provided wall-mounted double switch. This 3-wire cable is NOT supplied with the unit but is widely available (doorbell or thermostat cable is acceptable).

Step 2: Run wiring through electrical box and connect the control wiring to the wall switch wire leads – red (common), black and blue/white as shown in **Figure 7** below. Mount the wall switch in the electrical box. Secure the face plate once the connections have been made. Connect wire ends to the terminal block on the control board shown in **Figure 8**.

Step 3: Make sure the switch is in the off position before proceeding to **Start up and Operation**

The wall switch must be mounted in an approved electrical box large enough to accommodate the entering wires. Use approved methods such as wire nuts to connect wire ends.

FIGURE 7 – Wall Switch Wiring

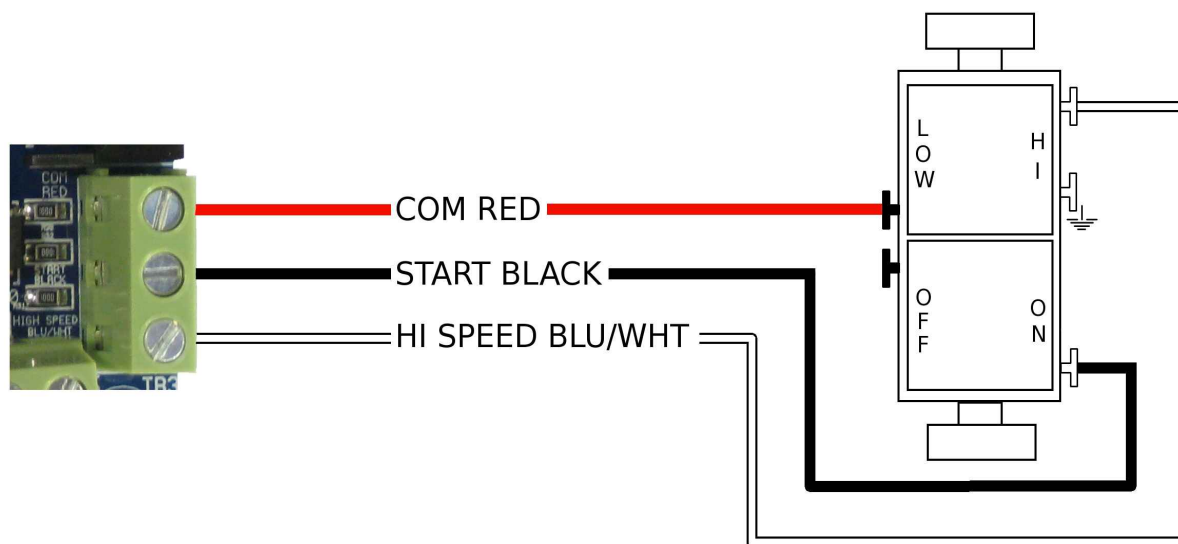
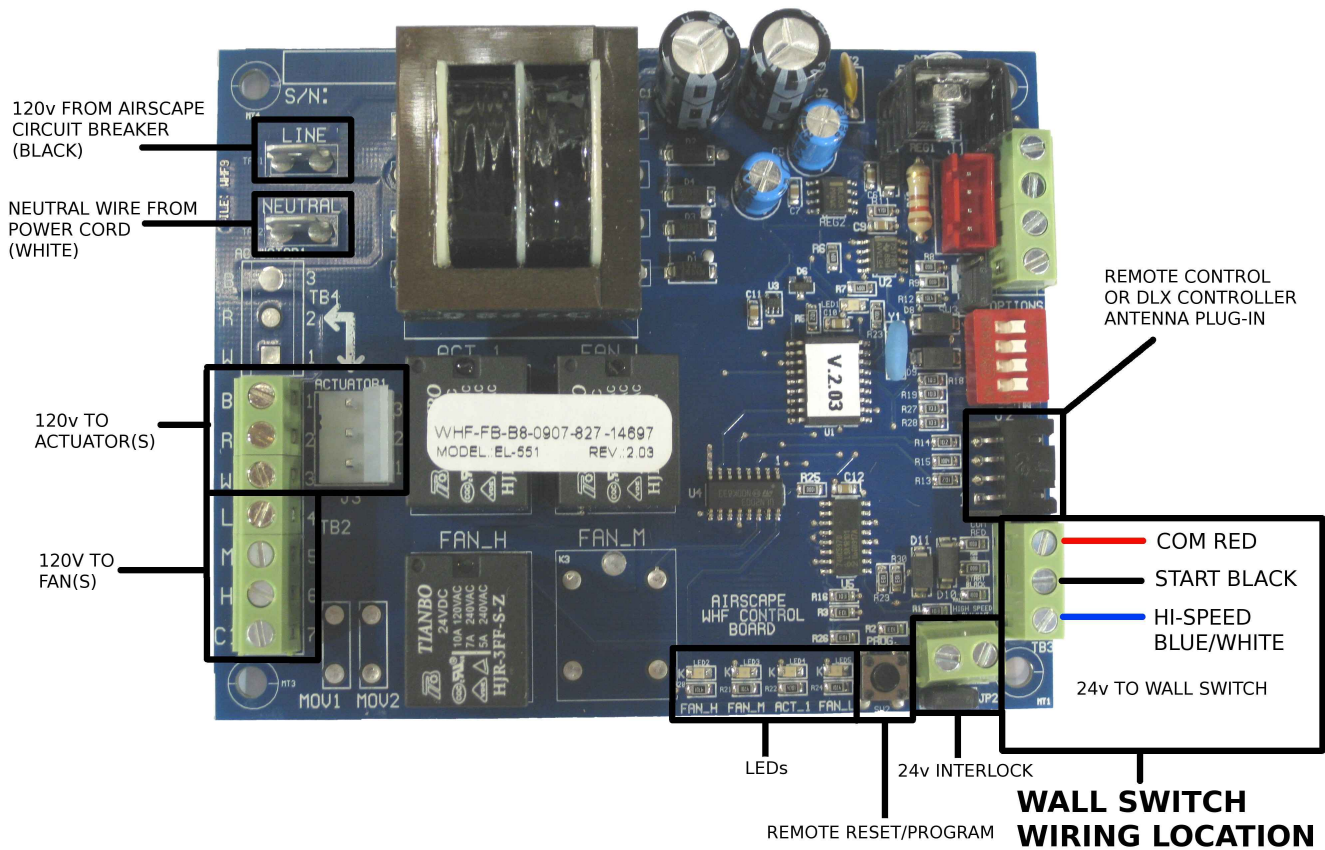

FIGURE 8 – Control Board Diagram



START UP AND OPERATION

- A dedicated circuit for this unit is NOT REQUIRED, but the power requirements of **120 volts, 1 amp (for the 1.0 model)** and **120 volts, 2 amp (for the 1.7 model)** must be taken into account when allocating power from existing electrical circuits.
- Make sure that all wiring and connections have been made per this manual and acceptable wiring standards.
- Make sure that no tools or construction debris have been left on or inside of the whole house fan.
- Plug the damper unit power cord into a 120-volt grounded outlet. Alternatively, if you would like to hardwire the unit, remove the power cord and provide 120-volt power to the unit through the circuit breaker located on the unit mounted junction box.
- Verify that the power switch is OFF and turn on electrical power at the circuit breaker.
- Turn the unit ON in LOW speed. The damper doors will take a few seconds to open and there will be a delay before the fans turn on. Once the fans start running, switch the unit to HIGH.
- When the power is turned OFF, the fans will shut down and the damper door(s) begin to close. The door(s) will shut tightly within 60 seconds.

TIMECLOCKS - AUTOMATED CONTROLS

Please contact AirScape at 866.448.4187 or by email experts@airscapefans.com for information on using a timeclock or other automated device with an AirScape Whole House Fan.

SAFETY INFORMATION



Not So Obvious – Please Read:

Do not operate the whole house fan without a window or door open.

This fan is meant for general ventilation. It has **NOT** been designed to vent particle laden and/or explosive mixtures of air.

If people or pets are expected to be in proximity to an operating whole house fan, there is risk of personal injury from the fan blades. If you feel this situation will occur, **DO NOT** operate the fan without a fan guard. Contact the manufacturer for more information on this subject.

Never force open the doors. Always use clutch releases located on actuators before attempting to manually open or close damper doors.

MAINTENANCE

There is no routine maintenance required for the 1.7/1.0 WHF other than to make sure that the fan blades and damper are kept clean of any possible build up of lint or other debris.

Blocking the fan discharge during operation could cause premature fan failure if internal temperatures rise to a very high level. Ensure that no items are placed within 2 feet of the fan discharge path.

A re-settable circuit breaker is located on the control box to protect the control board from power surges. To reset, simply push the button back in.

TROUBLESHOOTING



Before servicing the unit, switch power off at the electrical panel to reduce the risk of electrical shock, fire, or injury.

This AirScape Whole House Fan has been factory tested. If you have problems with the unit please take a few minutes to run through the following troubleshooting procedures before calling your installer or retailer.

Symptom: Unit does not start

Possible causes: No power to unit.

Suggestion 1: Check power to the unit and wiring at both the switch and the unit mounted junction box.

Suggestion 2: Verify that your circuit breaker has been turned back on.

Suggestion 3: If power is verified at the unit, remove all control wiring from the low voltage control side. Jumper 24COM RED terminal to START (BLK). The damper door(s) should open and the fans should start after a short delay. When the jumper is removed the fans should stop and the damper should close. If the start/stop sequence checks out then there is an issue with field wiring to the switch or remote.

Symptom: Dampers do not open

Possible causes: No power to damper actuator or damper shaft loose.

Suggestion for **1.7 Models**: Check power to unit and wiring. The actuator (actuator mounted terminal block, not circuit board) should always have 120v power to terminal 3, and terminal 2 only when the fans running (open damper). Terminal 1 should be the neutral. Verify that the actuator jaws are closed tight on the damper shaft.

Suggestion for **1.0 Models**: Check power to unit and wiring. The actuator (actuator mounted terminal block, not circuit board) should always have 120v power to terminal 2 and 4, and terminal 3 only when fans running (open damper). Terminal 1 should be the neutral. Verify that the actuator jaws are closed tight on the damper shaft.

Symptom: One or more fans do not run

Possible causes: Wiring issue with fan or damaged fan.

Suggestion: Verify factory fan wiring connections at circuit board.

Symptom: Unit does not run on low speed

Possible causes: Wiring issue.

Suggestion: Verify wiring connections to the low/high speed selector.

Symptom: Unit does not run on high speed

Possible causes: Wiring issue.

Suggestion: Verify wiring connections to the low/high speed selector.

If you continue to have issues with the unit or have questions about the installation and wiring, please contact the manufacturer or your local retailer.

LIMITED WARRANTY

Hardware

AirScape warrants the original end user (“Customer”) that new AirScape Whole House fan products, including all moving parts, motors, dampers, and damper actuators will be free from defects in workmanship and materials, under normal use, for three (3) years from the original purchase date.

Software

AirScape warrants to Customer that the AirScape Whole House Fan software will perform in substantial conformance to its program specifications for a period of three (3) years from the date of the original purchase.

Exclusions

This warranty excludes (1) physical damage to the surface of the product, including cracks or scratches on the outside casing; (2) damage caused by misuse, neglect, improper installation, unauthorized attempts to open, repair, or modify the product, or any other cause beyond the range of intended use; (3) damage, caused by accident, fire, power changes, other hazard, or Acts of God; or (4) use of the product with any unauthorized device if such device causes the problem.

Exclusive Remedies

Should a covered defect occur during the warranty period and Customer notifies AirScape, Customer's sole and exclusive remedy will be, at AirScape's sole option and expense, to repair or replace the product. Replacement products or parts may be new or reconditioned or a comparable version of the defective item. AirScape warrants any replaced product or part for a period of ninety (90) days from shipment, or through the end of the original warranty, whichever is longer.

Obtaining Warranty Service

Customer must contact and return product to AirScape, Product dealer or Installer within the applicable warranty period to obtain warranty service. Dated proof of original purchase will be required. AirScape will not be responsible for Customer's memory data contained in, stored on, or integrated with any products returned to AirScape for repair, whether under warranty or not.

Warranty Exclusive

The forgoing warranties and remedies are exclusive and in lieu of all other Warranties, express or implied, including warranties of merchantability, Fitness for a particular purpose, correspondence with description, and Non-infringement, all of which are expressly disclaimed by AirScape and its suppliers.

Disclaimer

Neither AirScape nor its suppliers shall be liable for incidental, consequential, indirect, special, or punitive damages of any kind, or financial loss arising out of or in connection with the sale or use of this product, whether based in contract, Tort (including negligence) or any other theory, even if AirScape has been advised of the possibility of such damages AirScape's entire liability shall be limited to replacement or repair of the product.

UNIT SPECIFICATIONS

Rough Opening:	14 ½" x 22 ½"
Grille Outer Dimensions:	16 ½" x 24 ½"
Grille Build:	Aluminum with cube core center - powder coated white
Electrical:	115 VAC, 60 Hz
Speeds:	2
Installation:	Installs easily between 16" O/C joists or 24" O/C joists.
Operation:	Dual SPST switch (Decora style). Supplied with unit. Optional remote control available. (Remote and wall switch not supplied together.)
Warranty:	3 years

1.0 WHF

Unit Size:	27 ¼" x 17 ¼" x 7" (LxWxH) - <i>Requires at least 20" of overhead clearance for the damper door to open fully</i>
Weight:	26 lbs
Fan Energy Consumption:	78/39 watts (high/low)
Airflow:	1047/600 CFM (high/low)
Acoustical:	53/43 dBA (high/low)

1.7 WHF

Unit Size:	27" x 22" x 13" (LxWxH)
Weight:	38 lbs
Fan Energy Consumption:	157/78 watts (high/low)
Airflow:	1712/1000 CFM (high/low)
Acoustical:	55/44 dBA (high/low)