

ORDER # _____
S/N: _____
(Required for warranty)

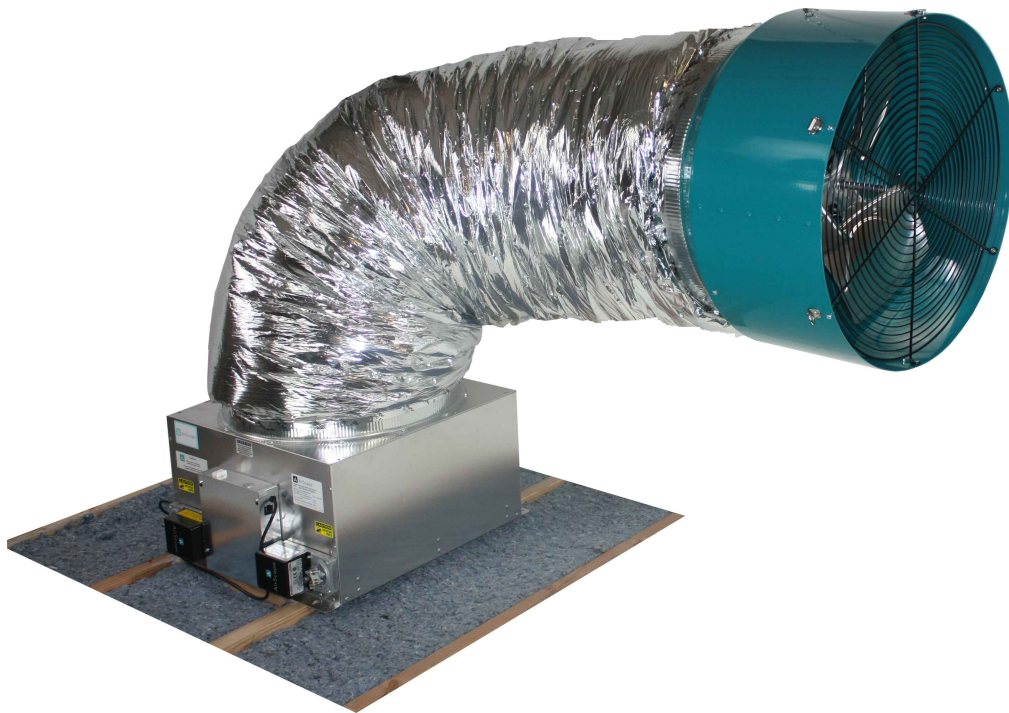

2.5/2.5E WHOLE HOUSE FAN INSTALLATION AND OPERATION MANUAL

© ALL RIGHTS RESERVED | AIRSCAPE INC.



WHAT'S INCLUDED

Prior to installation, please verify that you received all the accessories with the whole house fan. The packages should include:

- BOX 1 of 3: damper door enclosure with grille, IOM, 8 metal and 4 wood screws, 4 S-hooks, dual speed switch and plate **or** LCF Wireless Remote Kit **or** DLX Controller
- BOX 2 of 3: fan assembly, chain, duct tape
- BOX 2 of 3: Insulated acoustical flex duct

CONGRATULATIONS on your purchase of the AirScape 2.5/2.5e Whole House Fan. This fan is designed to provide you with quiet, natural, energy-efficient cooling for many years.

Please take a few minutes to read over the sections below to make sure you are prepared for the installation. The building owner/occupant should read the section "Where to locate" below so that the 2.5/2.5e WHF will be correctly located to maximize effectiveness and efficiency of operation.

If you (or your installer) have any questions regarding the installation, operation, or maintenance, please see AirScape technical support at www.airscapefans.com or call 1.866.448.4187.

WHAT YOU WILL NEED

- flat head screwdriver
- cordless screwdriver w/ Philips head bit and drill bits
- lumber, matching dimensions of the attic joists (2x6, 2x8, etc....)
- high quality latex caulk
- drywall cutter
- 3 wire cable 20g or larger (thermostat wire will work) and electrical box for mounting wall switch (Only if no other controller has been ordered with unit)

WHERE TO LOCATE

Let's start with a little theory of operation: As your house heats up during the summer day, a large amount of heat is retained in the building structure. Even though many summer evenings offer very comfortable outdoor conditions, we are forced to either endure the hot conditions of our houses or turn on the air conditioning and subject ourselves to the expense and possibly unhealthy air conditions.

AirScape Whole House Fans have been designed to run quietly and efficiently all night long. Building materials give up their heat slowly (touch the brick on your house after sunset), and this method of slow cooling extracts as much heat as possible from your house structure. Since the AirScape is one of the quietest whole house fans on the market, it also allows you to get a good night's sleep.

FIGURE 1 – Location

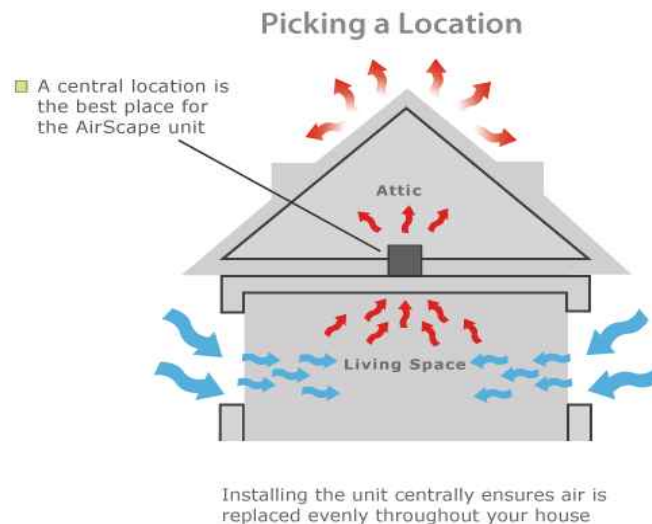

Guidelines for locating your whole house fan:

- Centrally located to ensure air is drawn evenly from multiple open windows
- AWAY from windows that will be opened so cool air is required to travel a long path to the fan
- At the highest point possible to exploit natural convective action
- Near an outlet or power supply to minimize electrical work
- Typically, the ideal location in a two-story home is in the open area at the top of the stairs
- Try avoid narrow spaces close to bedrooms, as this could amplify noise at night (when noise perception is strongest)

Ceiling or Wall?

The 2.5/2.5e WHF intake box can be mounted in either the horizontal or vertical orientation. Our recommended location is on a ceiling in the horizontal orientation -- keep in mind that it makes sense to place the unit as high as possible to eliminate the hottest air from the house.

REQUIRED VENTING AREA

For proper operation of your AirScape unit, it is CRITICAL that your attic has sufficient venting area; otherwise the hot air cannot easily escape and creates back-pressure that can substantially reduce the performance of your new whole house fan.

The “net-free” area of a vent is the total vent opening minus the loss caused by the interference of the screen, louver or grille covering the vent.

The AirScape 2.5/2.5e requires a **MINIMUM of 5** sq ft of "net free" venting area in your attic to allow for proper exhaust.

This means that it requires the equivalent of a 2 ft by 2½ ft unobstructed hole. Since most attics have multiple vents, often of different types, and since most vents are partially obstructed by grilles and/or bug/animal screens, you'll need to do some calculations to make sure your venting is sufficient. While it is our experience that most properly constructed houses have the required venting, not all do. And because this is so critical to the proper operation of your unit, it is important that you verify it.

Different types of vent designs have different ratios of obstruction caused by grilles and screening and manufacturers typically publish these numbers. If this information is not available to you, a ratio of 50% is a good rule of thumb. For example a typical 24" x 24" louver, with a gross area of 4 sq ft, would have a net free area of 2 sq ft.

Vent Type	Length	Width	Net Free Area (NFA%)	Calculation L x W x NFA / 144
Louver	16"	16"	50 %	= 16 x 16 x 0.5 / 144 = 0.89 sq ft
Ridge Vent	48"	not used	13 %	= 48 x 0.13 / 12 = 0.52 sq ft
Eave Vent	12"	4"	50 %	= 12 x 4 x 0.5 / 144 = 0.16 sq ft

- In practice, less net-free area than is recommended will decrease the airflow performance of the unit.
- If you are unsure as to how much net-free venting you have, please consult a roofing professional.
- Net-free venting area can be acquired by any combination of gable, eyebrow, soffit, or ridge vents, or any other means that provide ventilation to the attic space.

UNIT PARTS & DIMENSIONS

FIGURE 2 – Parts & Dimensions

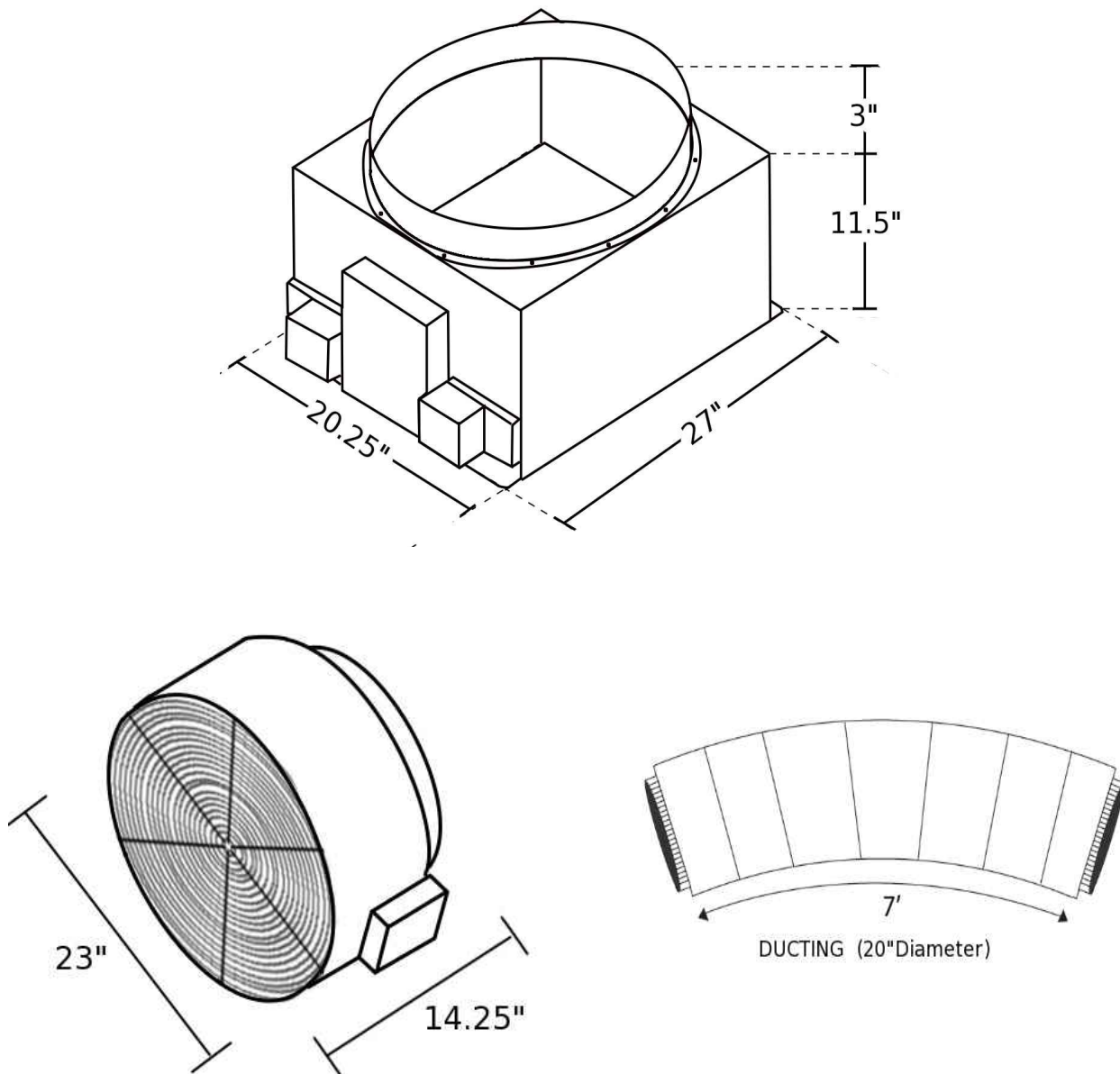

INSTALLATION - CARPENTRY

The 2.5/2.5e WHF has been designed to fit on top of a 14½" x 22½" wall or ceiling opening. Since most modern houses have been built with either 16" or 24" on-center (O/C) spaced joists or studs, a simple "box" is constructed in the wall/ceiling.

NOTE: There are two different installation methods determined by how the 2.5/2.5e will be inserted into the attic. Please follow the instructions that apply to your install.

There is an existing attic access large enough for the 2.5/2.5e fan to fit through:

16" O/C Framing

Step 1: Install two 14½" cross pieces creating a box with inside dimensions 14½" x 22½" (**Figure 3**).
Step 2: Cut out dry wall inside the framed box.

24" O/C Framing

Step 1: Install two 22½" cross pieces creating a box with inside dimensions of 14½" x 22½" (**Figure 3**).
Step 2: Cut out dry wall inside the framed box.

FIGURE 3 – 16" O/C Framing

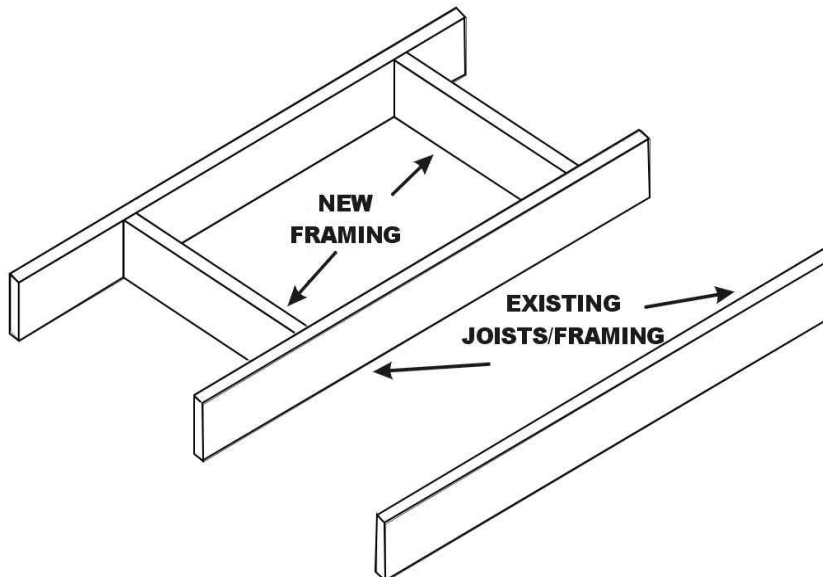

The 2.5/2.5e fan needs to fit through the hole that is framed for it:

16" O/C Framing

- Step 1: Cut out the dry wall between the joists to create a 23" x 14½" rough opening.
- Step 2: Fit the 2.5/2.5e fan through the rough opening and into the attic.
- Step 3: Install two 14½" cross pieces creating a box with inside dimensions of 14½" x 22½".
Make sure each cross piece partially covers the drywall cut out.
Approximately ¼" of each cross piece should be visible from below (**Figure 4**).

FIGURE 4 – 16" O/C Framing

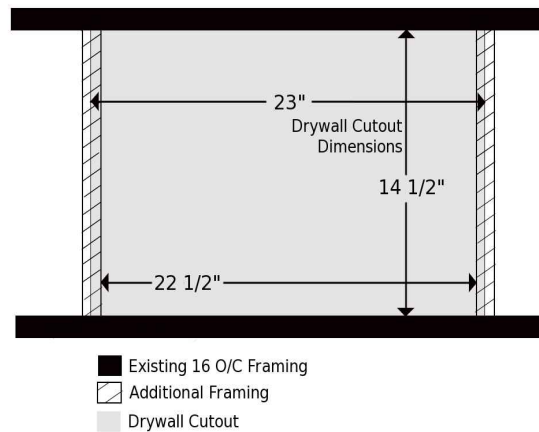

24" O/C Framing

- Step 1: Cut a 23" x 14½" opening in the dry wall, use an existing joist as the 23" long side.
- Step 2: Fit the 2.5/2.5e fan through the rough opening and into the attic.
- Step 3: Install cross pieces creating a box with inside dimensions of 14½" x 22½".
Make sure each cross piece partially covers the drywall cut out.
Approximately ¼" of each cross piece should be visible from below (**Figure 5**).

FIGURE 5 – 24" O/C Framing

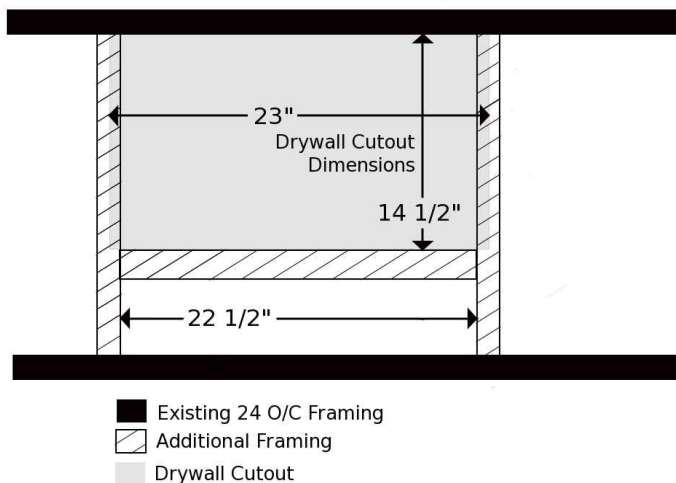

INSTALLATION - DAMPER BOX

Position the 2.5/2.5e damper enclosure on top of the joists so that the damper doors are aligned with the framed rough opening, being sure that there is easy access to the electrical box located on the side of the unit (**Figure 6**).

The actuator end of the damper box has two “key holes” which are used to attach the damper box to the joists. Mark the location of the “key holes” on the joists by placing the damper box over the rough opening. Remove the damper box and fasten two of the provided wood screws so that the screw head is slightly above the joist. Position the damper box over the “key holes” and slide to lock into position. Use the remaining screws to attach the opposite side of the damper box.

Use a good quality latex caulk to seal all wood-to-wood and wood-to-metal joints to create an airtight enclosure. This is important to ensure that all air drawn in by the fan will be from inside the house.

Attach the interior grille to the joists with the included wood screws.

FIGURE 6 – 2.5/2.5e WHF Damper Enclosure Installed

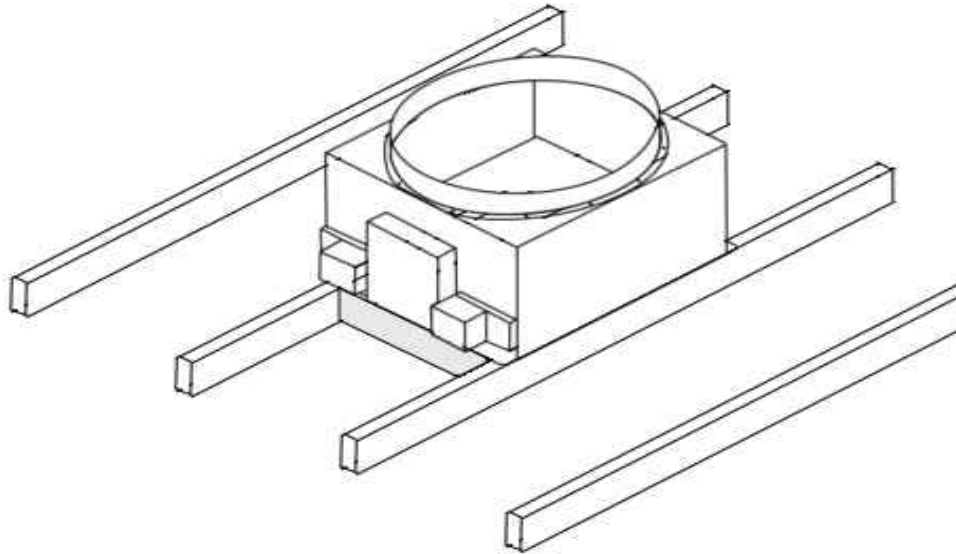

INSTALLATION - DAMPER COLLAR

- Remove the two screws that hold the damper collar in place for shipping.
- Position elliptical collar over damper box opening.
- Secure 2 screws (**Figure 7, step 1**).
- Stretch the collar until the 2 holes line up with the holes on the damper box body. Fasten with two screws (**Figure 7, step 2.1**).
- Fasten all remaining screws, including the 2 original screws (**Figure 7, step 2.2**).

FIGURE 7 – Damper Collar Installation

STEP 1:

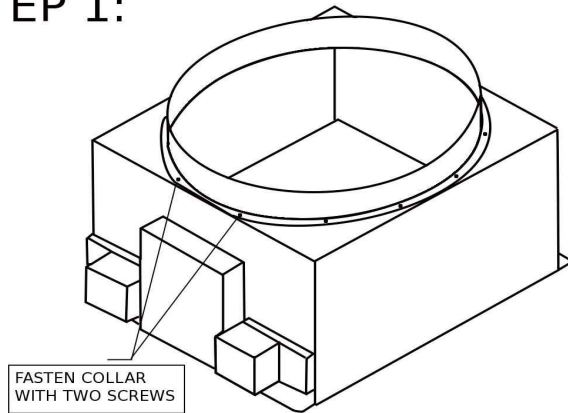

STEP 2:

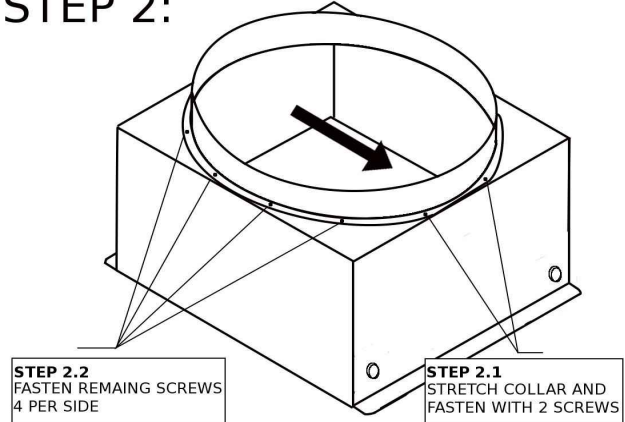

INSTALLATION – FAN AND DUCT

Attach 4 S-hooks to 4 of the D-hooks on the fan housing. Hang the fan from the attic rafters using 4 lengths of the supplied chain (**Figure 8**). The 4 lengths of chain are used to support the weight of the fan and to eliminate any swaying motion. Tape down any unused D-hooks to avoid excess rattling.

Slide one end of the flexible duct over the damper box collar and fasten with 4 self tapping sheet metal screws (**Figure 9**). Seal the joint with the included duct tape to make the seam airtight.

Attach the other end of the flexible duct to the collar on the back of the fan using the remaining sheet metal screws (**Figure 9**). Finish by wrapping the joint with the provided tape to make the seam airtight.

The duct should be gently bent 90 degrees for maximum sound attenuation and airflow (**Figure 10**). Avoid sharp bends in the duct or contact with metal fixtures, pipes, or conduits. The duct section immediately before the fan should be as straight as possible to ensure smooth airflow to the fan.

Once the fan is balanced and secure, close all S-hooks with pliers to ensure stability. Plug the fan control cord with the white male end into the white connector on the damper box.

Note: The 2.5e fan has a separate power cord that must also be plugged into a 120v outlet with uninterrupted power once all other installation has been completed.

FIGURE 8 – Hanging the Fan

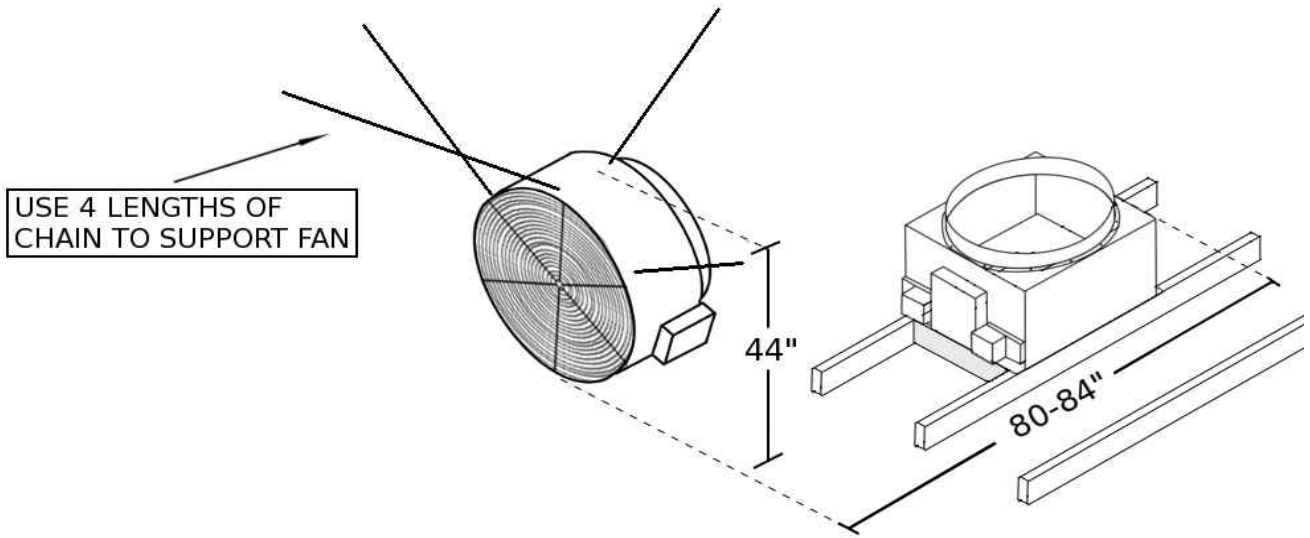

FIGURE 9 – Duct to Damper and Duct to Fan Connections

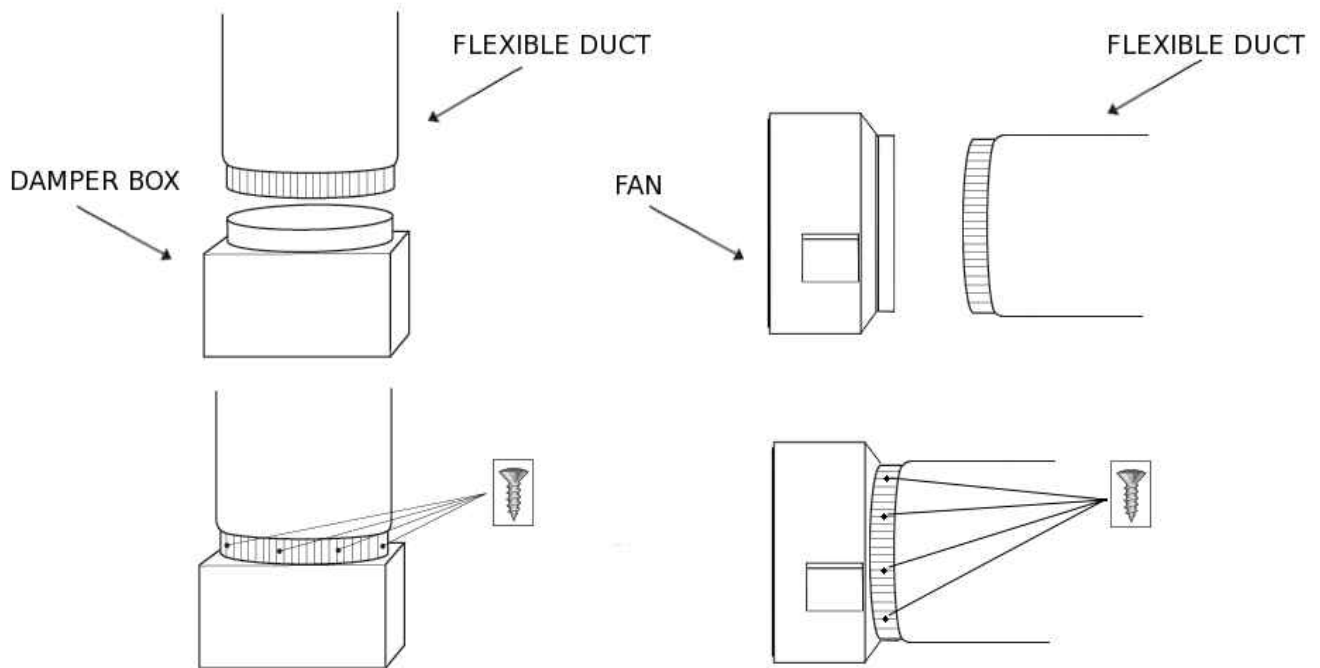
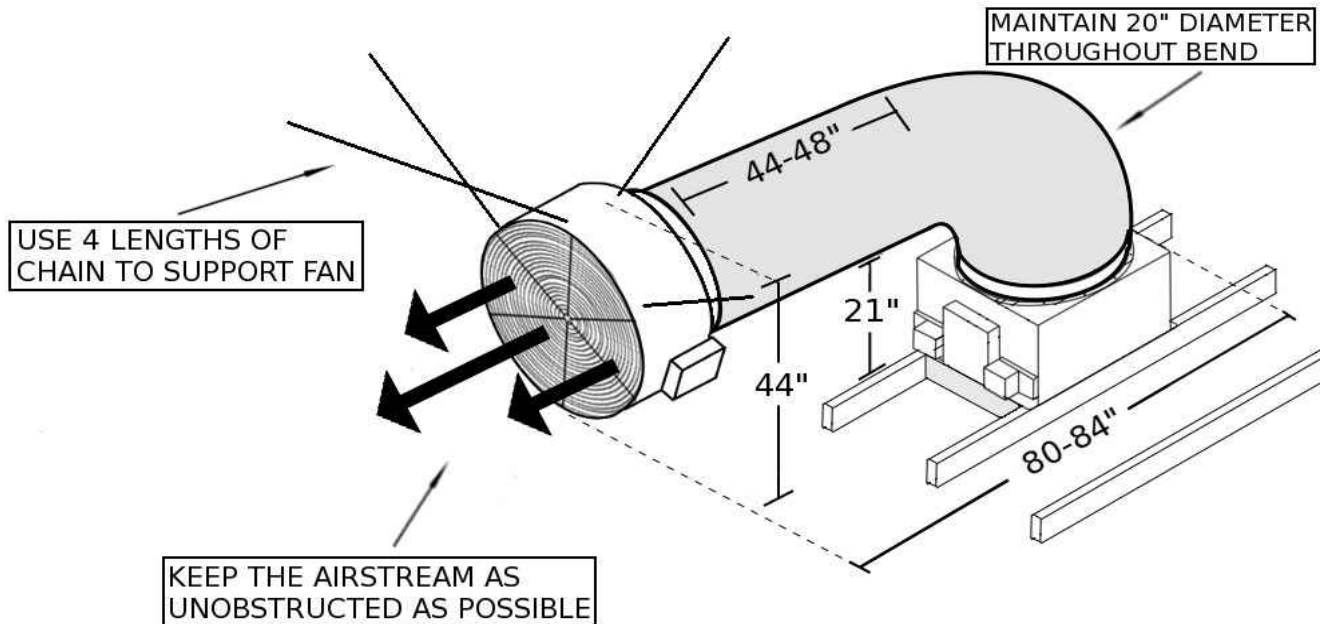

FIGURE 10 – Fully Installed View



INSTALLATION – WIRING (LOW VOLTAGE HARDWIRED SWITCH)



Please make sure that local codes and standards are followed when performing the following steps. Make sure that the appropriate circuit breakers are turned off and that the unit is unplugged when performing these steps.

*Note: If you purchased your unit with an optional DLX Controller see Controller IOM for installation instructions. If a Wireless Remote was purchased, it has already been installed on your unit. Skip to the **START UP AND OPERATION** section.*

Step 1: Run a 3-wire cable 20 gauge or thicker for the 24v low-voltage wiring from the damper enclosure to the provided wall-mounted double switch. This 3-wire cable is NOT supplied with the unit but is widely available (doorbell or thermostat cable is acceptable).

Step 2: Connect the control wiring with wire nuts to the three wire leads wired in the back of the wall switch – red, black and blue/white. Secure the face plate once the connections are made (**Figure 11**).

Step 3: Connect the wires to the terminal block on the circuit board (**Figure 12**).

Step 4: Make sure the switch is in the OFF position. When ready, plug in the two power cords (from the speed control and from the damper unit) into 120-volt outlets with uninterrupted power.

The wall switch must be mounted in an approved electrical box large enough to accommodate the entering wires. Use approved methods such as wire nuts to connect wire ends.

FIGURE 11 – Low Voltage Wall Switch Wiring

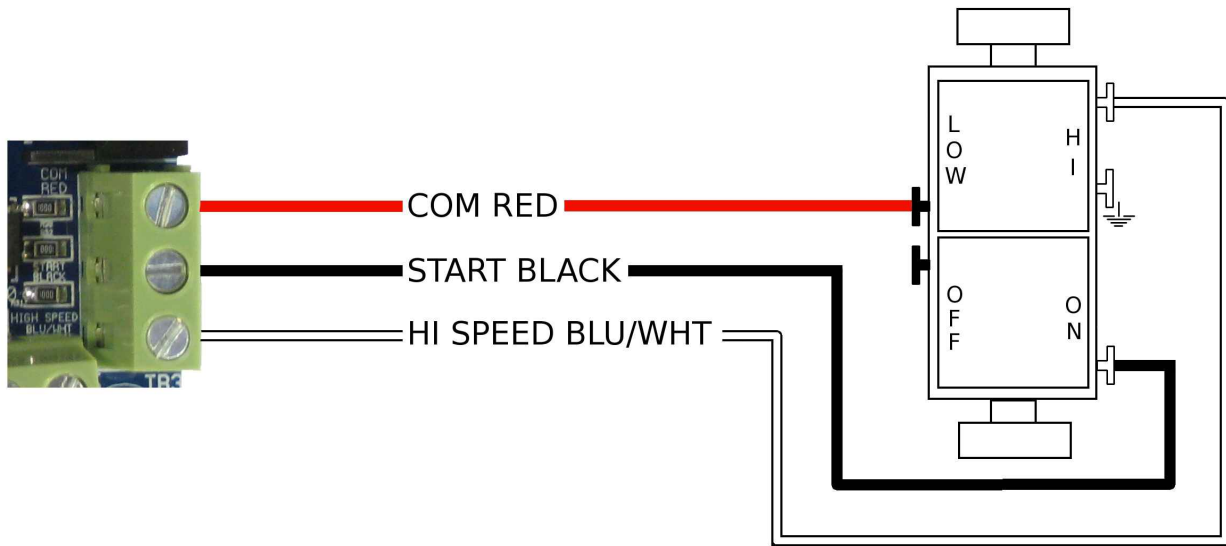
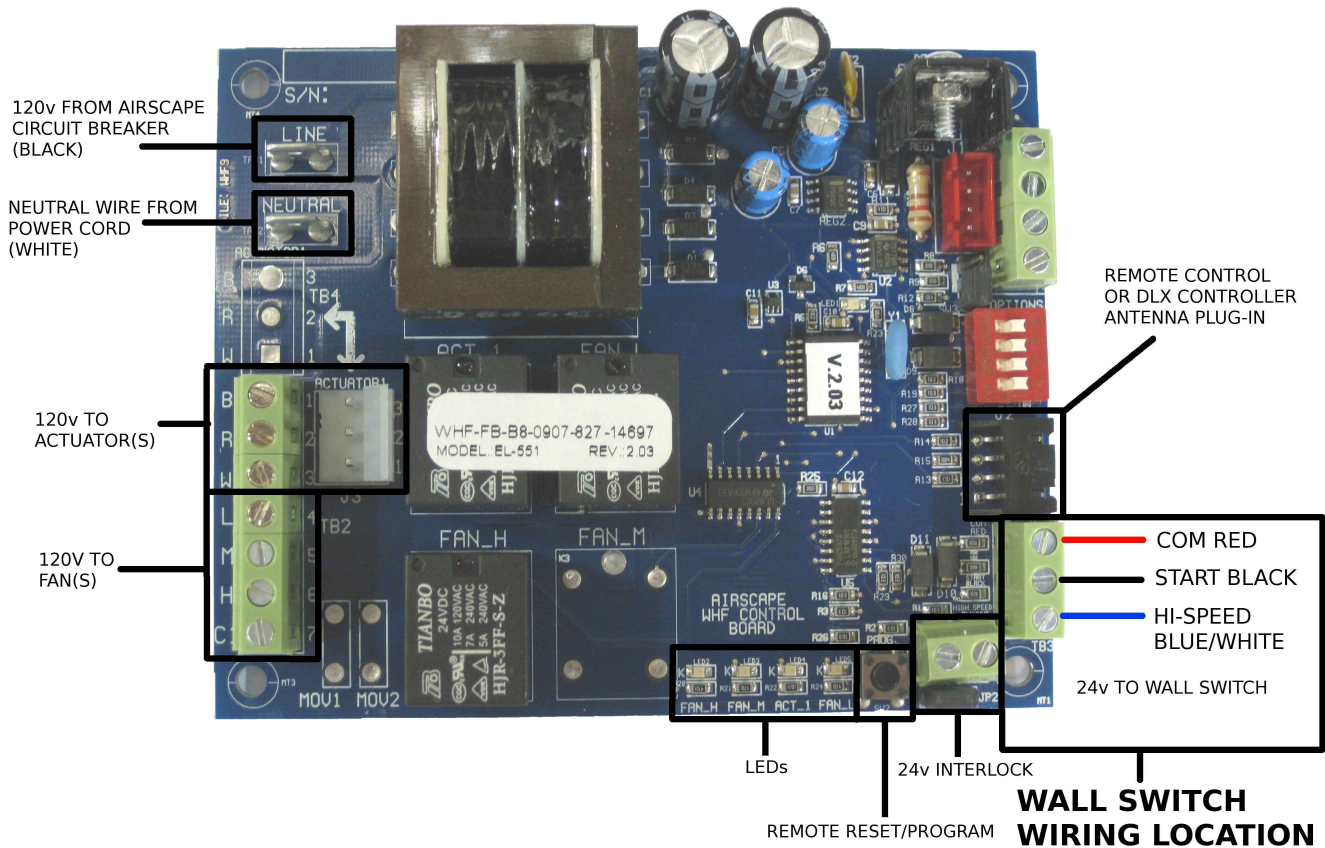

FIGURE 12 – Control Board Diagram



START UP AND OPERATION

- Make sure that all wiring and connections have been made per this manual and acceptable wiring standards and that all local codes and standards have been followed in the installation of this unit.
- Make sure that no tools or construction debris have been left in the 2.5/2.5e WHF.
- Plug the damper unit power cord into a 120-volt grounded outlet. Alternatively, if you would like to hardwire the unit, remove the power cord and provide 120-volt power to the unit through the circuit breaker located on the unit mounted junction box. A dedicated circuit is not required, however the power requirements of 120 volts, 2.5 amps must be taken into account when allocating power from existing circuits.
- The 2.5e WHF has a second power cord running from the fan that must also be plugged into a 120-volt grounded outlet. We do not recommend hardwiring the 2.5e fan power.
- Verify that the 2.5/2.5e WHF power switch is OFF and turn on electrical power at circuit breaker.
- Turn the unit ON in LOW speed. The damper doors will take a few seconds to open and there will be a delay before the fan turns on. Once the fan starts running, switch the unit to HIGH.
- When the power is turned OFF, the fan will shut down and the damper door begin to close. The door will shut tightly within 60 seconds.
- Allow for a slight delay when changing between speeds for the fan to adjust torque.

SAFETY INFORMATION



Not So Obvious - Please Read:

- Do not operate the 2.5/2.5e WHF without a window or door open.
- This fan is meant for general ventilation. It has **NOT** been designed to vent particle laden and/or explosive mixtures of air.
- Not for use in kitchens.
- Never force open the doors. Always use clutch releases located on Actuators before attempting to manually open or close damper doors.

IMPORTANT OPERATING TIPS

- Only use it when the outdoor air is cooler than your indoor air.
- Make sure your A/C is off when you run the fan or you'll be blowing expensive conditioned air right out of your house!
- We recommend running your AirScape all night long.
Here's why: The goal is to cool your entire house down, not just the air. It takes time to pull the heat out of the structure and contents of a house. By ventilating all through the night, the house starts the next day cooler so you can delay or eliminate running air conditioning the next day. AirScape Whole House Fans are very energy efficient so running on low speed through the night will only cost pennies.
- Use high speed to quickly cool down the house and low speed to run quietly through the night.
- Never operate the unit without opening a window – this can create negative pressure in the house and cause dangerous back drafting with gas appliances.
- You can control where the cooling effect is focused by which windows you open. Visualize the path the air will take between the open windows and the unit. Generally, the longer the path, the more overall cooling effect.
- If your home has a basement, extra cooling effect can be achieved by drawing air in through the basement windows.

MAINTENANCE

- There is no routine maintenance required for the 2.5/2.5e WHF other than to make sure that the fan blades and damper are kept clean of any possible build up of lint or other debris.
- Blocking the fan discharge during operation could cause premature fan failure if internal temperatures rise to a very high level. Ensure that no items are placed within 2 feet of the fan discharge path.
- A re-settable circuit breaker is located on the control box to protect the control board from power surges. To reset, simply push the button back in.

TIMECLOCKS - AUTOMATED CONTROLS

Please contact AirScape at 866.448.4187 or by email experts@airscapefans.com for information on using a timeclock or other automated device with an AirScape Whole House Fan.

TROUBLESHOOTING



Before servicing the unit, switch power off at the electrical panel to reduce the risk of electrical shock, fire, or injury.

The 2.5/2.5e WHF has been factory tested. If you have problems with the unit please take a few minutes to run through the following troubleshooting procedures before calling for assistance.

Symptom: Unit does not start

Possible causes: No power to unit.

Suggestion 1: Check power to the unit and wiring at both the switch and the unit mounted junction box.

Suggestion 2: Check the re-settable circuit breaker on damper enclosure electrical box.

Suggestion 3: If power is verified at the unit, remove all control wiring from the low voltage control side. Jumper COM (RED) terminal to START (BLK) terminal. Jumper testing must be done with power supplied to the unit. The unit will not operate if jumper wires are attached to unit prior to supplying power to the unit. The damper door should open and the fan should start. When the jumper is removed the fan should stop and the damper should close. If the start/stop sequence checks out then there is an issue with field wiring to the switch or remote.

Symptom: Damper does not open

Possible causes: No power to damper actuator or damper shaft loose.

Suggestion: Check power to unit and wiring. The actuator (actuator mounted terminal block, not circuit board) should always have power to terminal 3, and terminal 2 when the fan is running (open damper). Terminal 1 should be the neutral. Verify that the actuator jaws are closed tight on the damper shaft.

Symptom: Unit does not run on low speed

Possible causes: Wiring issue.

Suggestion: Verify wiring connections to the wall switch and the 120v wires from the control board to the fan. (shown in **Figure 12** on page 11).

Symptom: Unit does not run on high speed

Possible causes: Wiring issue.

Suggestion: Verify wiring connections to the wall switch and the 120v wires from the control board to the fan. (shown in **Figure 12** on page 11).

Symptom: Damper door opens but fan does not start

Possible causes: Wiring issue between fan and damper enclosure.

Suggestion: Verify all wiring connections between fan and damper enclosure electrical box.

If you continue to have issues with the unit, or have questions about the installation and wiring, please contact AirScape technical support by email at experts@airscapefans.com or call 1-866-448-4187.

LIMITED WARRANTY

Hardware

AirScape warrants the original end user (“Customer”) that new AirScape Whole House fan products, including all moving parts, motors, dampers, and damper actuators will be free from defects in workmanship and materials, under normal use, for three (3) years from the original purchase date.

Software

AirScape warrants to Customer that the AirScape Whole House Fan software will perform in substantial conformance to its program specifications for a period of three (3) years from the date of the original purchase.

Exclusions

This warranty excludes (1) physical damage to the surface of the product, including cracks or scratches on the outside casing; (2) damage caused by misuse, neglect, improper installation, unauthorized attempts to open, repair, or modify the product, or any other cause beyond the range of intended use; (3) damage, caused by accident, fire, power changes, other hazard, or Acts of God; or (4) use of the product with any unauthorized device if such device causes the problem.

Exclusive Remedies

Should a covered defect occur during the warranty period and Customer notifies AirScape, Customer’s sole and exclusive remedy will be, at AirScape’s sole option and expense, to repair or replace the product. Replacement products or parts may be new or reconditioned or a comparable version of the defective item. AirScape warrants any replaced product or part for a period of ninety (90) days from shipment, or through the end of the original warranty, whichever is longer.

Obtaining Warranty Service

Customer must contact and return product to AirScape, Product dealer or Installer within the applicable warranty period to obtain warranty service. Dated proof of original purchase will be required. AirScape will not be responsible for Customer’s memory data contained in, stored on, or integrated with any products returned to AirScape for repair, whether under warranty or not.

Warranty Exclusive

The forgoing warranties and remedies are exclusive and in lieu of all other Warranties, express or implied, including warranties of merchantability, Fitness for a particular purpose, correspondence with description, and Non-infringement, all of which are expressly disclaimed by AirScape and its suppliers.

Disclaimer

Neither AirScape nor its suppliers shall be liable for incidental, consequential, indirect, special, or punitive damages of any kind, or financial loss arising out of or in connection with the sale or use of this product, whether based in contract, Tort (including negligence) or any other theory, even if AirScape has been advised of the possibility of such damages AirScape’s entire liability shall be limited to replacement or repair of the product.

UNIT SPECIFICATIONS

Damper Box Size:	27"x20.25"x14.25" -- LxWxH
Duct Length:	7 feet
Duct Diameter:	20"
Rough Opening:	14.5"x22.5"
Grille Outer Dimensions:	16"x24"
Grille Build:	Aluminum with cube core center - powder coated white
Electrical:	115 VAC, 60 Hz
Speeds:	2
Installation:	Installs easily between 16" O/C joists or 24" O/C joists.
Operation:	Dual SPST switch (Decora style). Supplied with unit. Optional remote control available. (Remote and wall switch not supplied together.)
Insulation:	R10 insulated damper doors
Warranty:	3 years

2.5 WHF

Fan Energy Consumption:	292 watts at full speed
Airflow - High Speed:	2516 CFM high
Airflow - Low Speed:	2110 CFM
Acoustical:	51 dBA high / 48 dBA low

2.5e WHF

Fan Energy Consumption:	197 watts high speed, 44 watts low speed
Airflow - High Speed:	2536 CFM
Airflow - Low Speed:	1530 CFM
Acoustical:	50 dBA high / 37 dBA low